

When a cost effective large capacity scanning solution is required the TR70 will accommodate range of baggage sizes up to 600mm x 400mm with no length limit.

The TR70's innovative image recognition tools provide automatic material discrimination so that screeners can quickly and easily identify the material composition of scanned objects. In addition it offers options such as (TIP) Threat Image Projection; a virtual image management tool ensuring operators are always maximising the screening potential of the scanner.

Equipped with 2 x 22" LED monitors, and the ability to rotate the image and zoom up to 64x, the TR70 enables the operator to view items in colour and in black and white simultaneously to maximise interpretation of the screened items.

The multi function keyboard provides control of all key functions from simply starting and stopping the band, image management and storage, energy stripping, contrast function, edge enhance, penetration level, zoom and management of storage of previous scanned items.

ENHANCED DETECTION

Management tools such as energy stripping can be utilised to further interrogate screened items, determining material composition as organic, inorganic or metallic.

The addition of ADS (Advanced Detection System) software further enhances the ability to detect threat or contraband items. The algorithm will highlight suspect packages by encapsulating them on the screen - suspected explosives in red, cash/money in green and narcotics will be in yellow.

DATA MANGEMENT



The requirement to store records of screening sessions and the ability to recall images is managed via the on board data system. The 250GB of storage will capture session information by date and by user, facilitating the recall of specific images or time scales. If required, images in turn can be exported in TIF- or JPEG format including transmission to PC via Ethernet or USB to flash drive.

The ability to investigate even the most challenging of packages is achieved via the powerful dual energy X-ray source, which provides superior imaging performance and penetration of steel up to 32mm whilst remaining film safe to ISO 1600/33 DIN.

EQUIPPED FOR CHALLENGING ENVIRONMENTS

All the steel exterior panels and modern design equips the TR70 for environments where robust construction is a must. Different operational environments and volume of throughput means the scanner can be configured with a combination of roller tables to suit.

The TR70 complies with relevant performance standards for ionizing radiation-emitting products, electronics products, and radio frequency devices, qualification of screening personnel, occupational noise exposure and occupational safety and health standards.

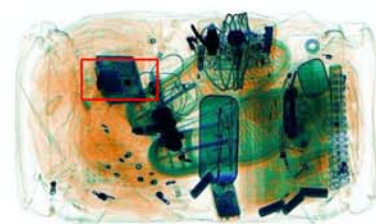

Example of ADS

TR70 Features and Benefits

Feature	Benefit
Image Enhancement	
Organic/ Inorganic material discrimination	Visualisation Users can select to highlight the presence of materials within a specific group e.g. Metallic.
Continuous zoom 2x and rotational zoom 64x	Images can be rotated 360° to view suspected materials in another profile. Users are also able to zoom in to interrogate specific areas.
Reversal of image	To achieve greater definition of an item the image colouration can be reversed. E.g. white on black or black on white.
Pseudo Colour	This function assigns colour to different grey scale levels to increase contrast between areas of similar absorption.
Variable edge enhancement	This Auto Focus enables the outline of items such as wires and components to be more comprehensively defined.
High/Low density adjustment	The image can be enhanced to further define areas of different density making compounds such as plastic explosives easier to detect.
Density alarm	Density levels can be set by %. When an item containing materials at the set density is scanned an alarm is raised prompting the operator to further interrogate the package. Preset density level will notify the operator by colour the suspect material
Data Management	
Image & session archiving	Scanning sessions can be archived by date, time and operator and subsequently recalled for review.
Networkable	Data sharing, report management from a supervisor station, central archiving.

Product Specification		
Dimensions: (mm) 2280(L) 905(W) 1255(H) Weight 450 kg	Inspection Tunnel: (mm) 606(W) 405(H)	Power supply: Monophase 230VAC+/-10%
Max bag weight: 165 (kg)	Conveyor belt height: 680mm	Power Absorption ≤1.5VA
Belt Speed: 0.2m/s	Duty cycle: 100%	Beam orientation: diagonally upwards
Resolution: AWG 41 mm typical Penetration: 32 mm typical	Detectors: 2x L shape rows of photodiodes	Leakage dose@10cm: <1.0µSv/hour(0.1mR/h)
Operational Temp:0°C-40°C Storage Temp: -20°C-+40°C	Humidity: 95% without condensation	Noise Level: <60dB(A) Film Safe: to ISO1600/33DIN

TR70 – Front View

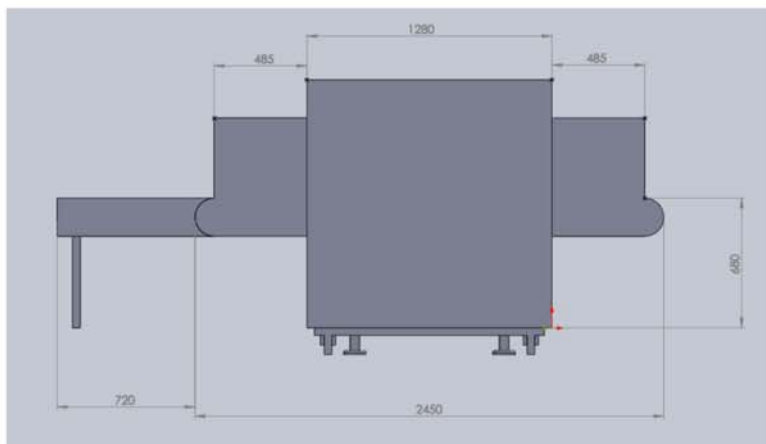

TR70 – Side View

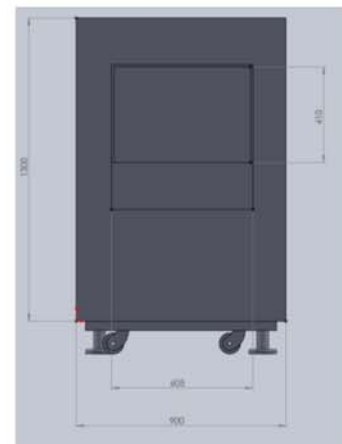

Supply Plus Limited Standard Terms & Conditions apply E&OE



Innovation Award Winner –
International Counter Terror Expo

